

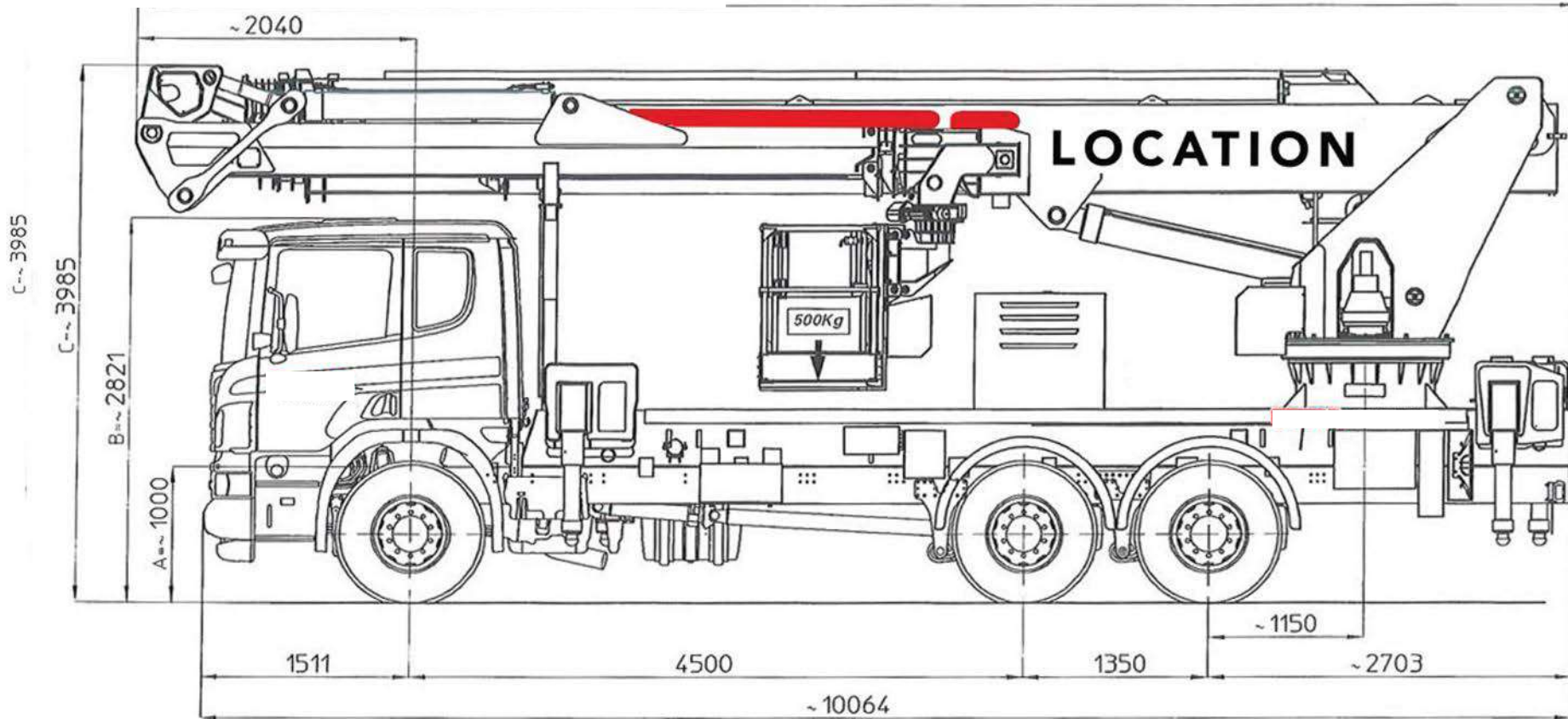

LOCATION BTP & SERVICES

www.fls.fr

Nacelle PL 45 m



STABILIZZAZIONE AUTOCARRI PTT < 26 TON.

LARGHEZZA MASSIMA 2540mm.

STABILISATION VEHICULES PTAC < 26 TON.

LARGEUR MAXI 2540mm.

TRUCK STABILISATION FOR GVW < 26 TON.

AND MAX WIDTH 2540mm.

ABSTUTZUNG FUR FAHRZEUG MIT GES. GEWICHT < 26 TON.

UND MAX. BREITE 2540mm.

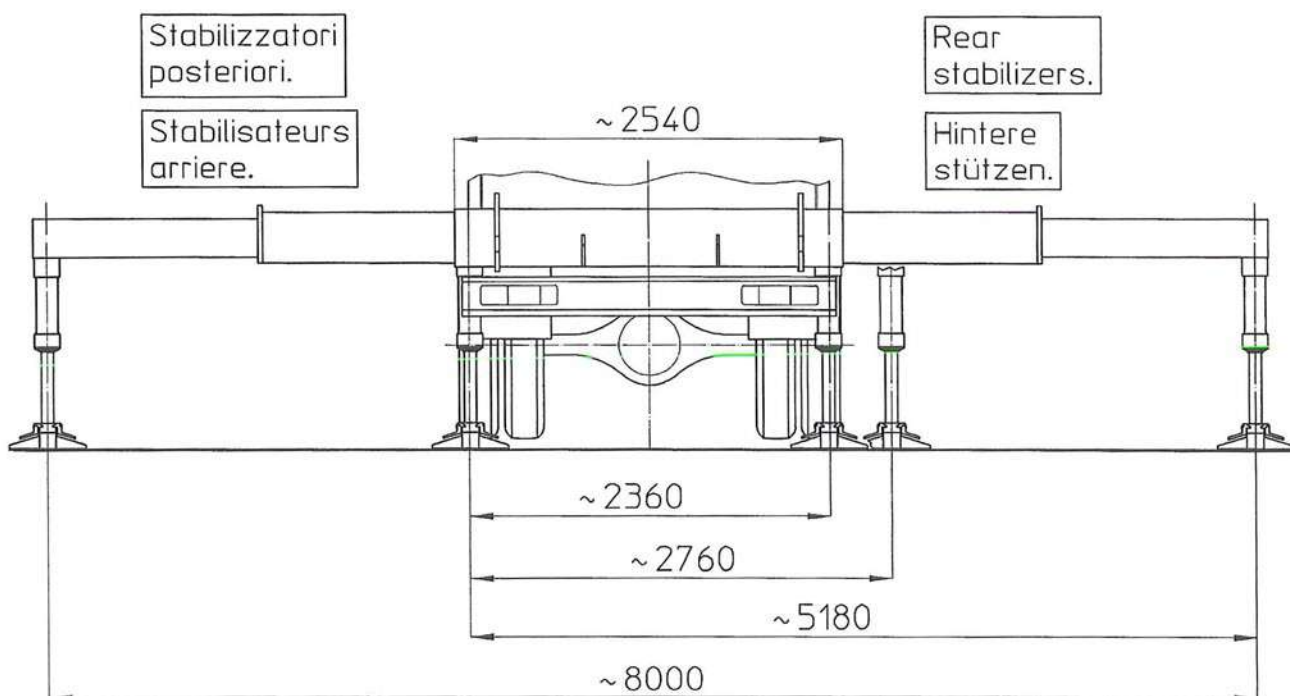
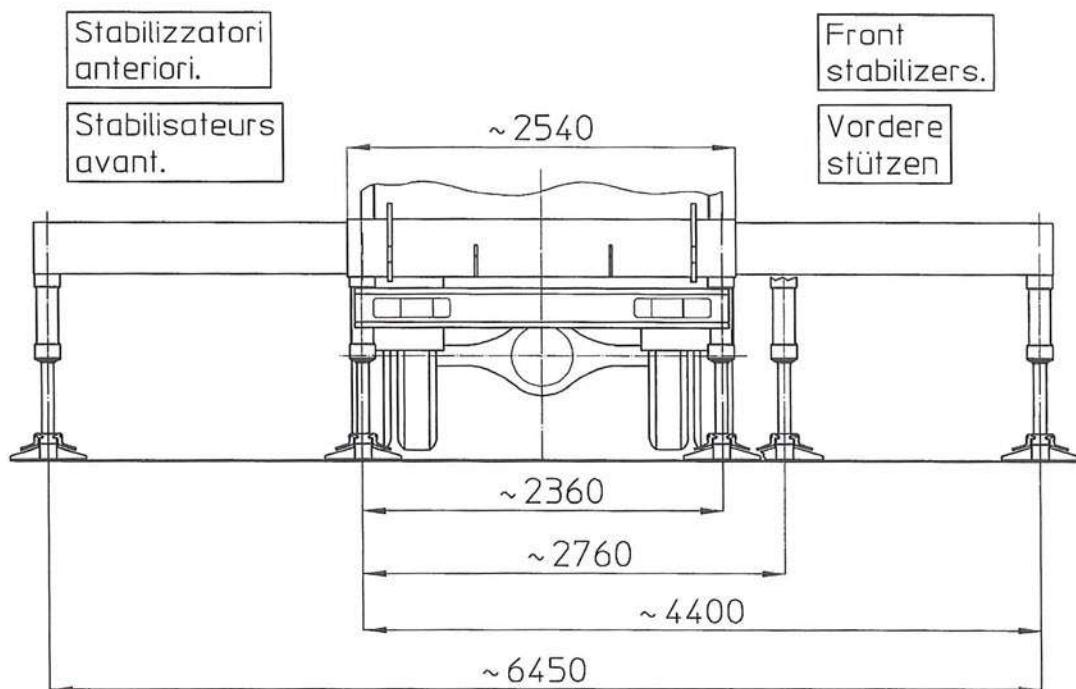

Ente	Rev.	Descrizione	Data	Dis.	Contr.	Ap.AQ
MRK	0	EMISSIONE	06/06/14	R.F.		

INGOMBRO - SCHEDA 54/1 - Rev. 0 - 15/12/00

D52332

MULTITEL MJ450

Ente	Rev.	Descrizione	Data	Dis.	Conlr.	Ap.A0
MRK	0	EMISSIONE	25/02/16	L.B.		
DIAGRAMMA - SCHEDA 54/2 - Rev. 0 - 15/12/00						

D55955

300Kg

P.T.T.=26000 kg
 G.V.W.=26000 kg
 P.T.A.C.=26000 kg
 GES. GEWICHT=26000 kg

STABILIZZATORI PARZIALMENTE ESTESI (~250mm)
 PARTIALLY EXTENDED STABILIZERS (~250mm)
 STABILISATEURS ETENDUS PARTIELLEMENT (~250mm)
 PARTIAL AUSGEFAHRENE STÜTZEN (~250mm)

SBRACCIO DI LAVORO 12,4 m ±5%
 WORKING OUTREACH 12,4 m ±5%
 DEPORT DE TRAVAIL 12,4 m ±5%
 SEITLICHE REICHWEITE 12,4 m ±5%

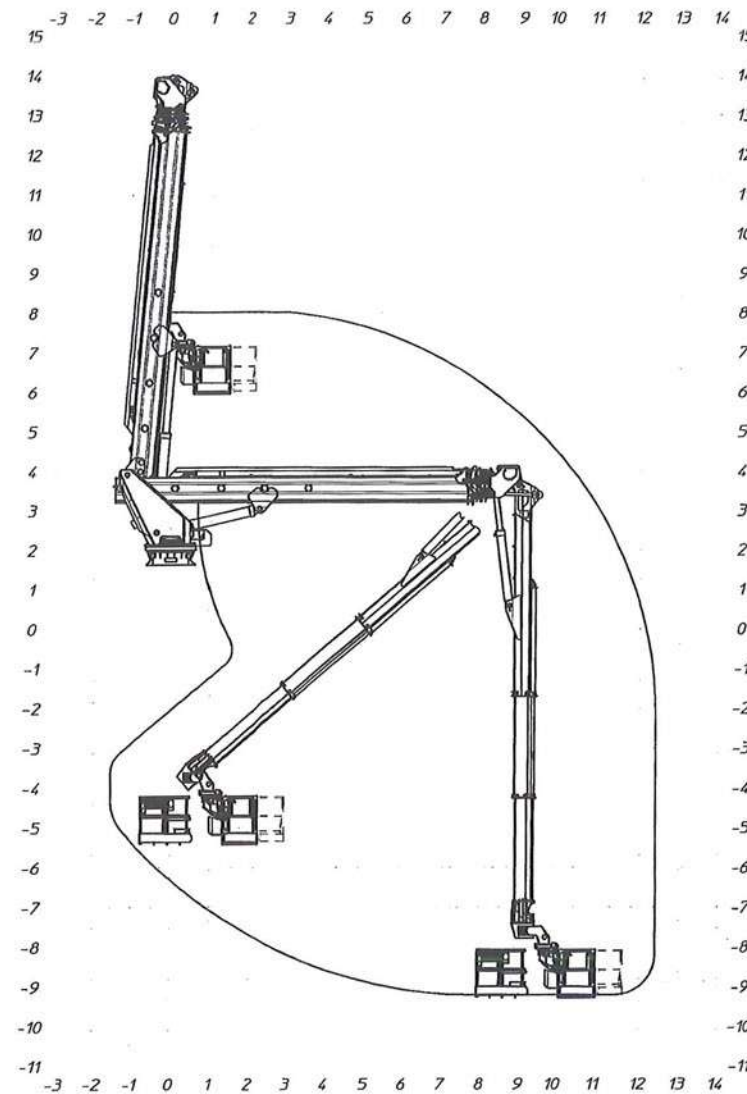
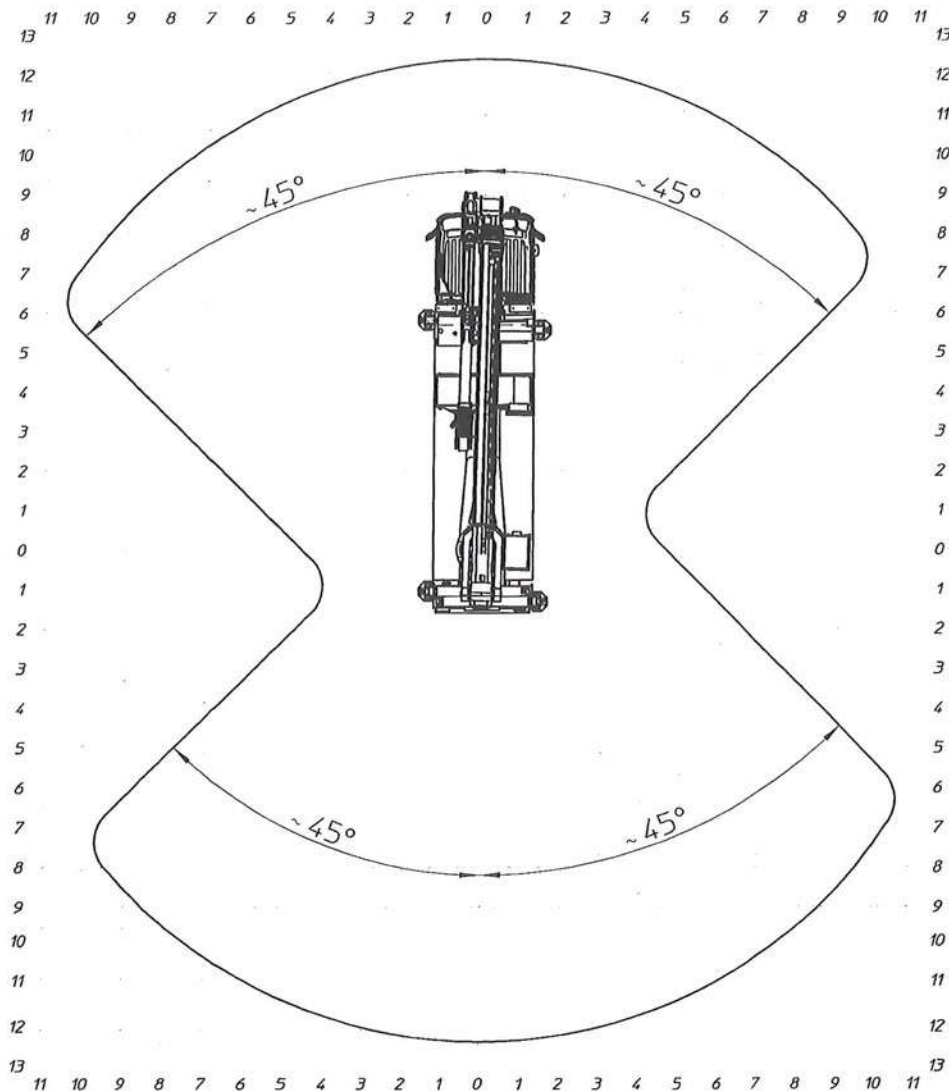

MULTITEL MJ450

Ente	Rev.	Descrizione	Data	Dis.	Contr.	Ap.A0
MRK	0	EMISSIONE	31/01/17	L.B.		
DIAGRAMMA - SCHEDA 54/2 - Rev. 0 - 15/12/00						

D55951-F

P.T.T.=26000 kg
 G.V.W.=26000 kg
 P.T.A.C.=26000 kg
 GES. GEWICHT=26000 kg

STABILIZZATORI PARZIALMENTE ESTESI (~750mm)
 PARTIALLY EXTENDED STABILIZERS (~750mm)
 STABILISATEURS ETENDUS PARTIELLEMENT (~750mm)
 PARTIAL AUSGEFAHRENE STÜTZEN (~750mm)

300kg
 SBRACCIO DI LAVORO 12,4 m ±5%
 WORKING OUTREACH 12,4 m ±5%
 DEPORT DE TRAVAIL 12,4 m ±5%
 SEITLICHE REICHWEITE 12,4 m ±5%

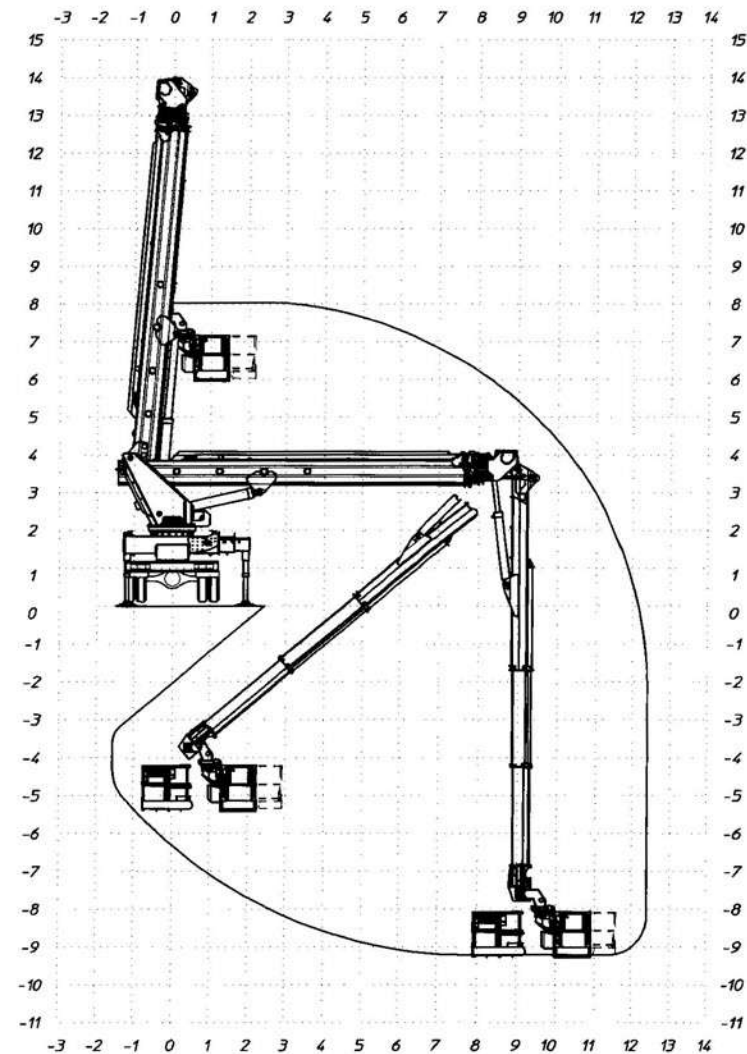
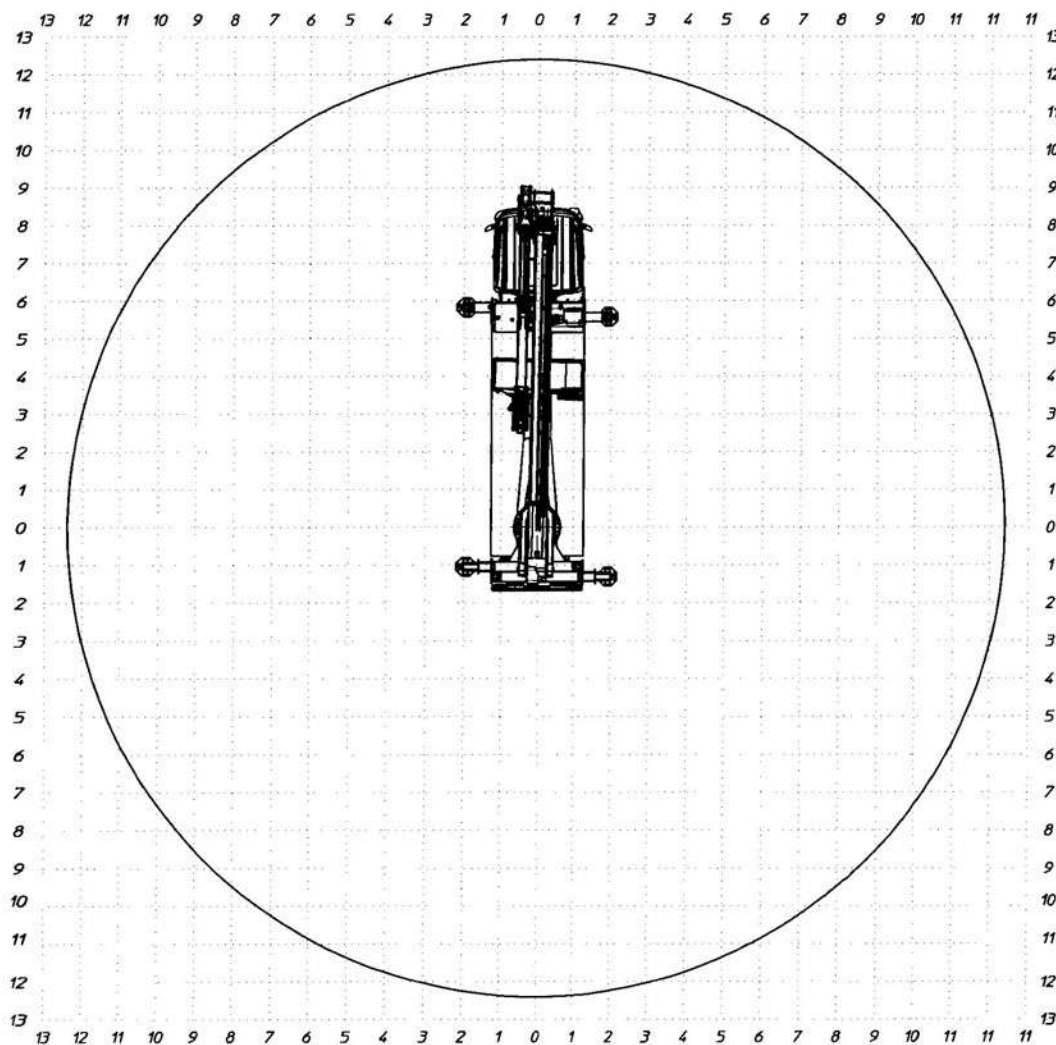

MULTITEL MJ450

Ente	Rev.	Descrizione	Data	Dis.	Contr.	Ap.A0
MRK	0	EMISSIONE	14/02/17	L.B.		

DIAGRAMMA - SCHEDA 54/2 - Rev. 0 - 15/12/00

D56023-P

P.I.T.=26000 kg
 G.V.W.=26000 kg
 P.T.A.C.=26000 kg
 GES. GEWICHT=26000 kg

STABILIZZATORI COMPLETAMENTE ESTESI
 FULLY EXTENDED STABILIZERS
 STABILISATEURS COMPLETEMENT ETENDUS
 GANZ AUSGEFAHRENE STÜTZEN

SBRACCIO DI LAVORO
 WORKING OUTREACH
 DEPORT DE TRAVAIL
 SEITLICHE REICHWEITE

	500Kg	300Kg	120Kg
SBRACCIO DI LAVORO	26,7 m ±5%	30,3 m ±5%	32,3 m ±5%
WORKING OUTREACH	26,7 m ±5%	30,3 m ±5%	32,3 m ±5%
DEPORT DE TRAVAIL	26,7 m ±5%	30,3 m ±5%	32,3 m ±5%
SEITLICHE REICHWEITE	26,7 m ±5%	30,3 m ±5%	32,3 m ±5%

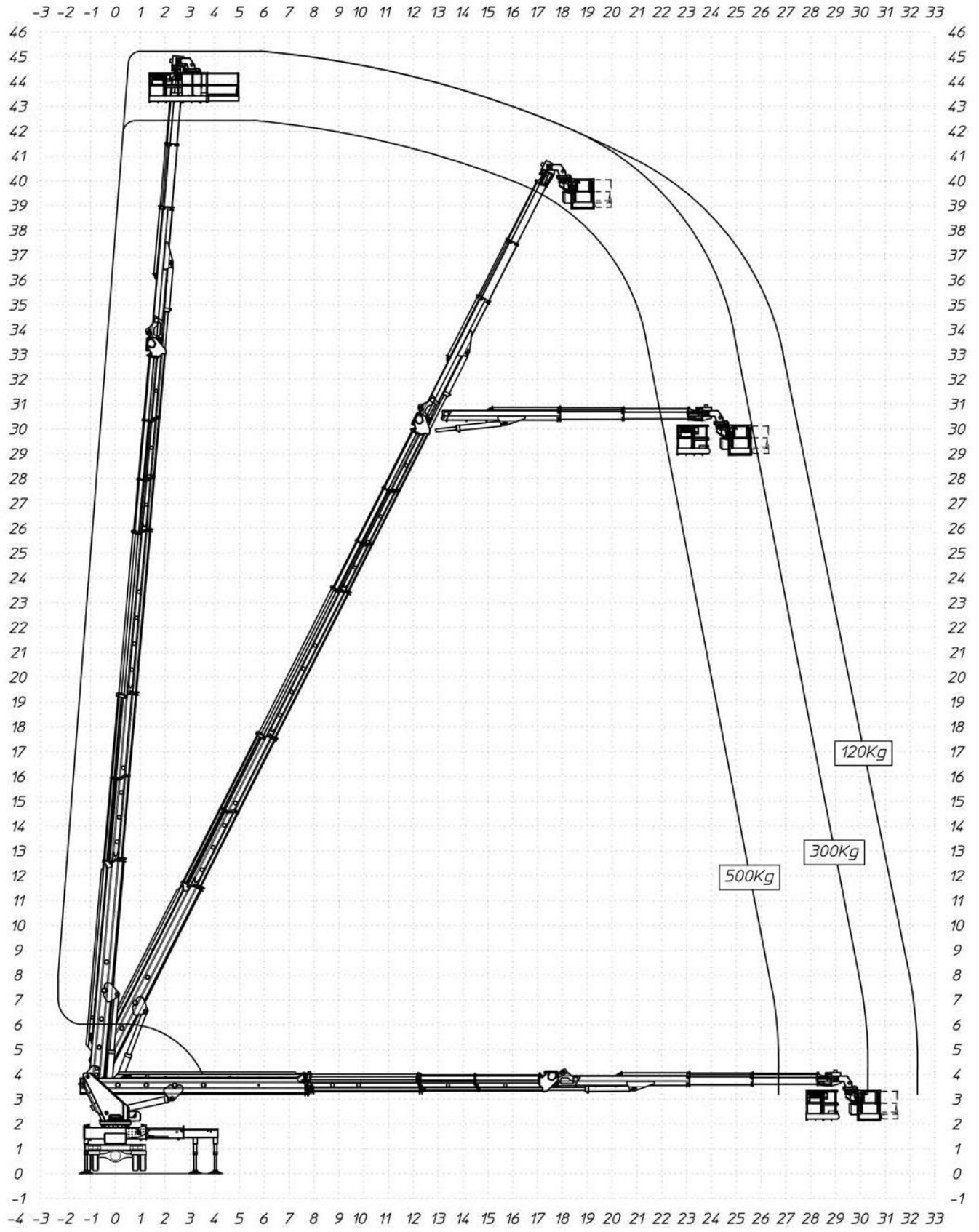

MULTITEL MJ450

Ente	Rev.	Descrizione	Data	Dis.	Contr.	Ap.A0
MRK	0	EMISSIONE	29/10/15	L.B.		
DIAGRAMMA - SCHEDA 54/2 - Rev. 0 - 15/12/00						

D54954

P.T.T.=26000 kg
 G.V.W.=26000 kg
 P.T.A.C.=26000 kg
 GES. GEWICHT=26000 kg

STABILIZZATORI IN SAGOMA
 STRAIGHT LINE STABILIZERS
 STABILISATEURS EN GABARIT
 STÜTZEN INNERHALB DER FAHRZEUGBREITE

SBRACCIO DI LAVORO
 WORKING OUTREACH
 DEPORT DE TRAVAIL
 SEITLICHE REICHWEITE

500Kg	300Kg	200Kg	120Kg
14,3 m ±5%	17,1 m ±5%	17,6 m ±5%	17,9 m ±5%
14,3 m ±5%	17,1 m ±5%	17,6 m ±5%	17,9 m ±5%
14,3 m ±5%	17,1 m ±5%	17,6 m ±5%	17,9 m ±5%
14,3 m ±5%	17,1 m ±5%	17,6 m ±5%	17,9 m ±5%

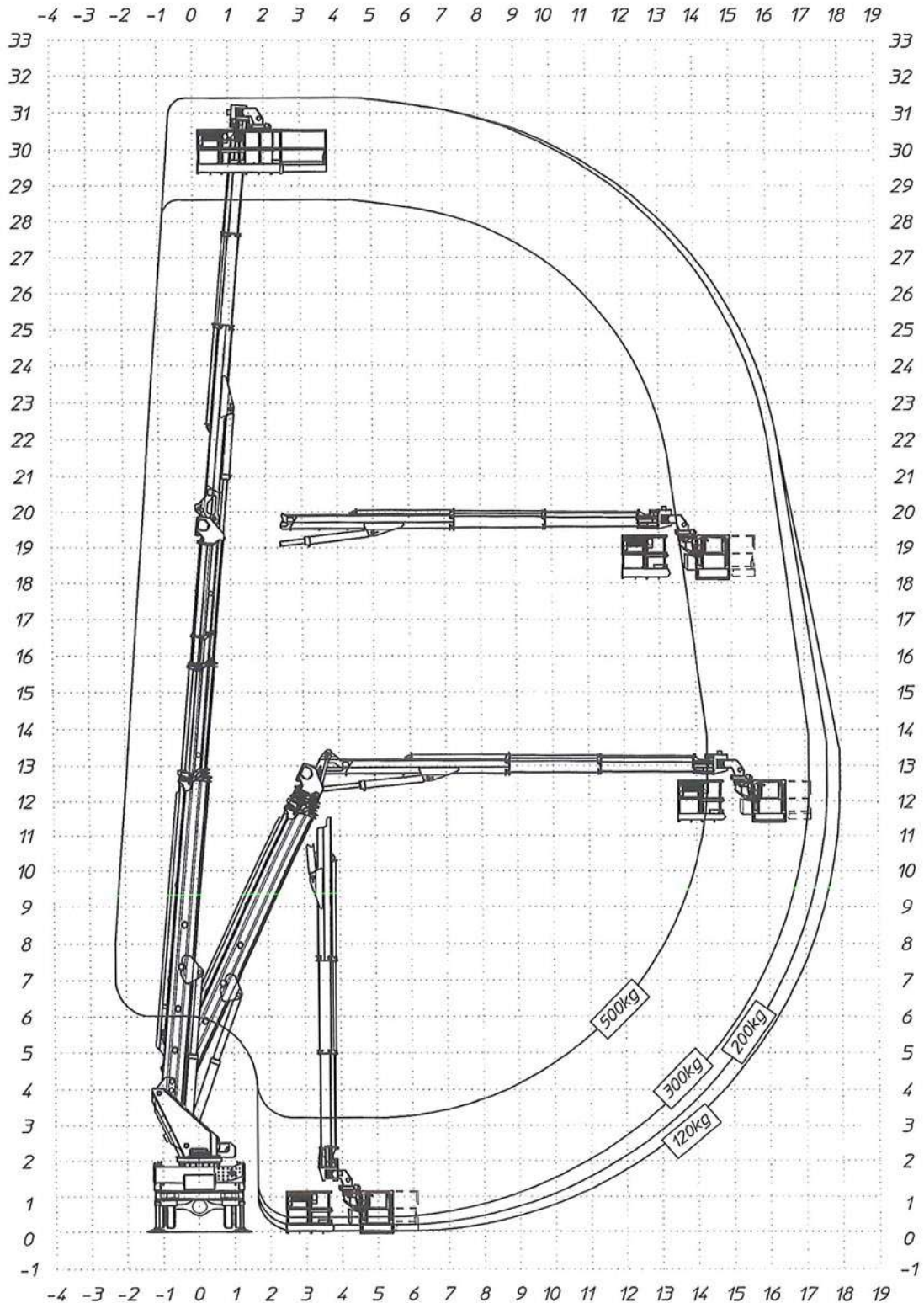

MULTITEL MJ450

Ente	Rev.	Descrizione	Data	Dis.	Contr.	Ap.A0
MRK	0	EMISSIONE	24/02/16	L.B.		
DIAGRAMMA - SCHEDA 54/2 - Rev. 0 - 15/12/00						

D55951

P.T.T.=26000 kg
 G.V.W.=26000 kg
 P.T.A.C.=26000 kg
 GES. GEWICHT=26000 kg

STABILIZZATORI PARZIALMENTE ESTESI (~750mm)
 PARTIALLY EXTENDED STABILIZERS (~750mm)
 STABILISATEURS ETENDUS PARTIELLEMENT (~750mm)
 PARTIAL AUSGEFAHRENE STÜTZEN (~750mm)

300kg
 SBRACCIO DI LAVORO 12,4 m ±5%
 WORKING OUTREACH 12,4 m ±5%
 DEPORT DE TRAVAIL 12,4 m ±5%
 SEITLICHE REICHWEITE 12,4 m ±5%

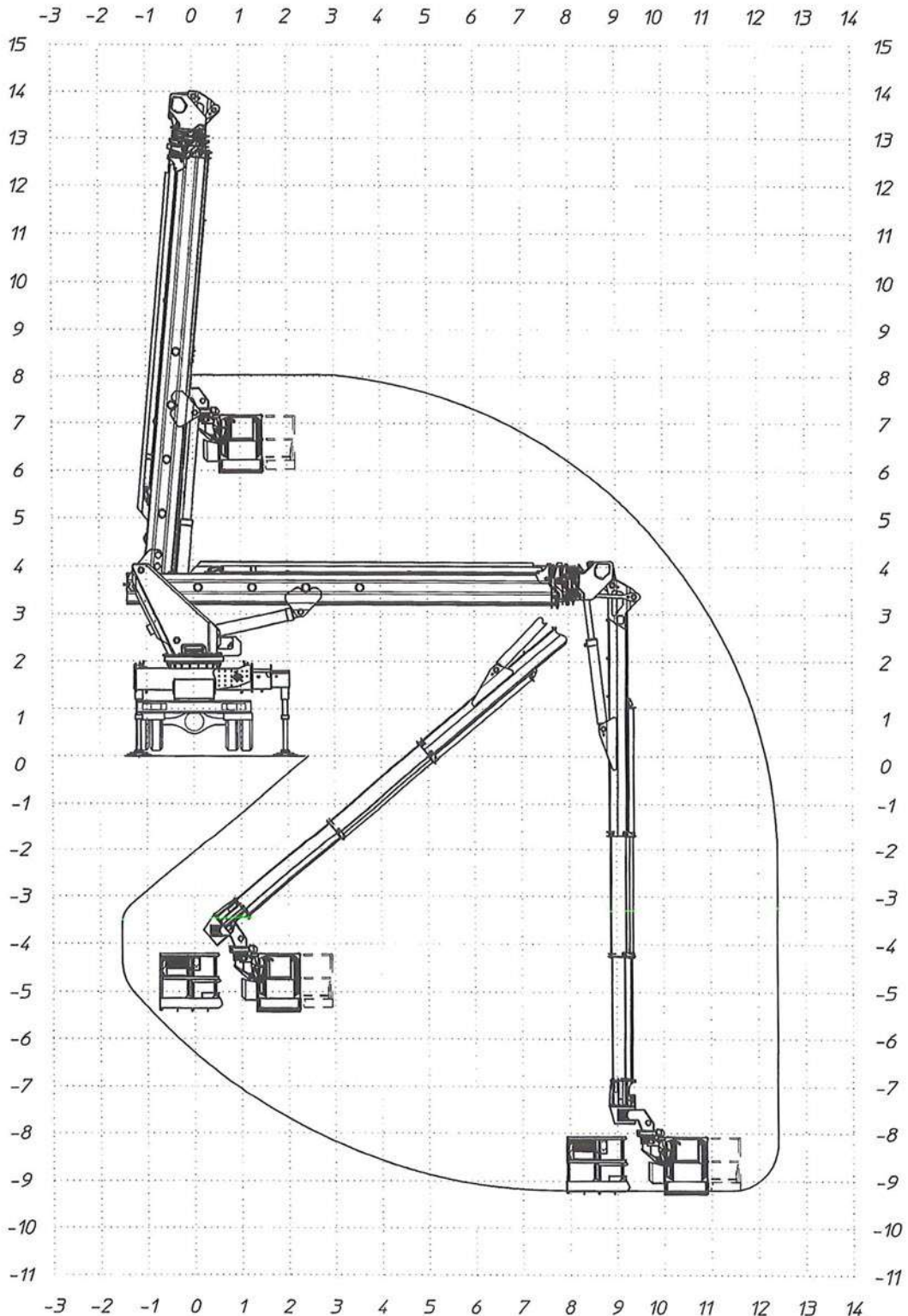

MULTITEL MJ450

Ente	Rev.	Descrizione	Data	Dis.	Contr.	Ap.A0
MRK	0	EMISSIONE	04/11/15	L.B.		
DIAGRAMMA - SCHEDA 54/2 - Rev. 0 - 15/12/00						

D54971

P.T.T.=26000 kg
 G.V.W.=26000 kg
 P.T.A.C.=26000 kg
 GES. GEWICHT=26000 kg

STABILIZZATORI PARZIALMENTE ESTESI (~900mm)
 PARTIALLY EXTENDED STABILIZERS (~900mm)
 STABILISATEURS ETENDUS PARTIELLEMENT (~900mm)
 PARTIAL AUSGEFAHRENE STÜTZEN (~900mm)

300kg
 SBRACCIO DI LAVORO 12,4 m ±5%
 WORKING OUTREACH 12,4 m ±5%
 DEPORT DE TRAVAIL 12,4 m ±5%
 SEITLICHE REICHWEITE 12,4 m ±5%

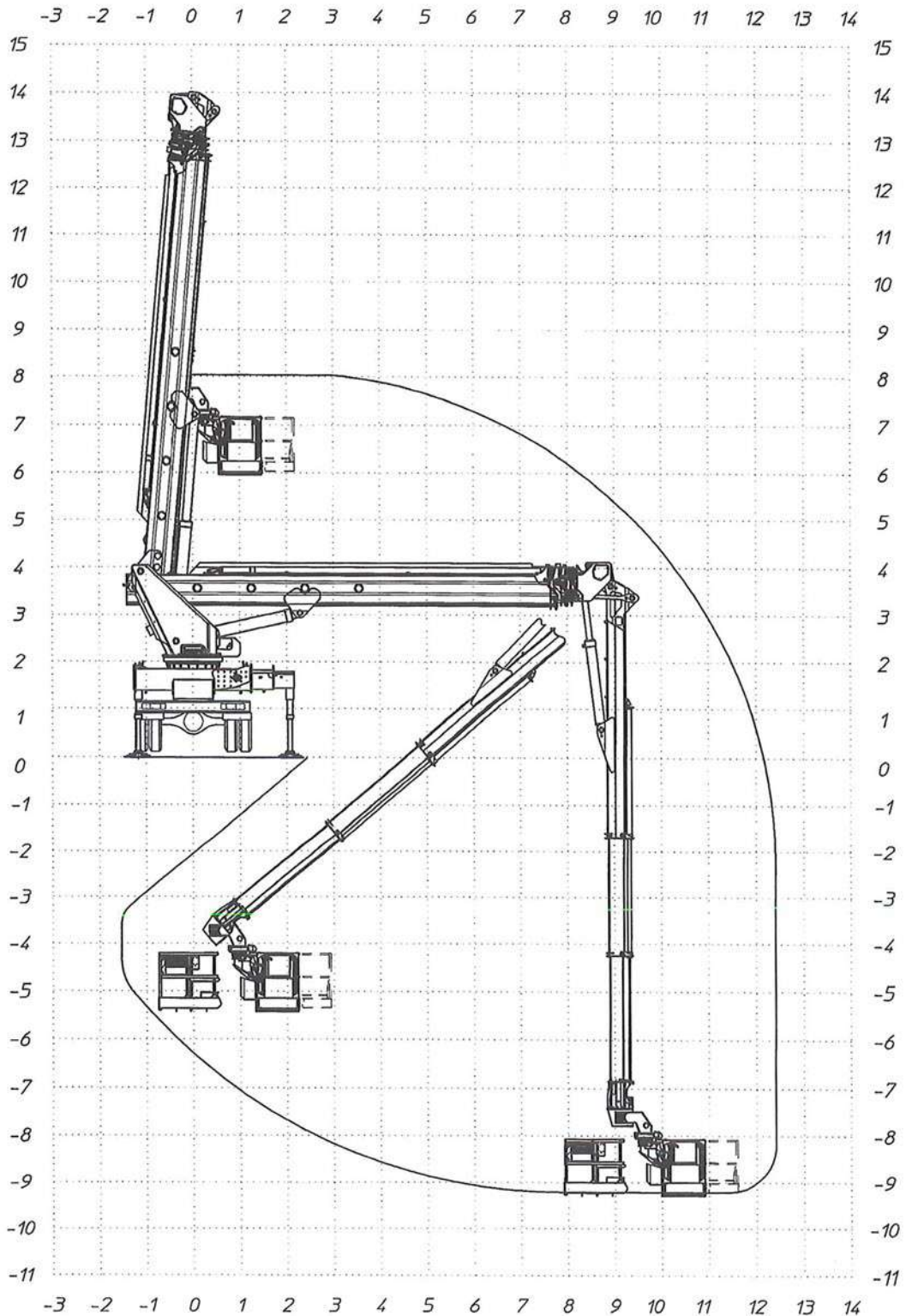

MULTITEL MJ450

Ente	Rev.	Descrizione	Data	Dis.	Contr.	Ap.AQ
MRK	0	EMISSIONE	14/02/17	L.B.		
DIAGRAMMA - SCHEDA 54/2 - Rev. 0 - 15/12/00						

D56023-N

P.T.T.=26000 kg

G.V.W.=26000 kg

P.T.A.C.=26000 kg

GES. GEWICHT=26000 kg

STABILIZZATORI COMPLETAMENTE ESTESI

FULLY EXTENDED STABILIZERS

STABILISATEURS COMPLETEMENT ETENDUS

GANZ AUSGEFAHRENE STÜTZEN

SBRACCIO DI LAVORO

WORKING OUTREACH

DEPORT DE TRAVAIL

SEITLICHE REICHWEITE

500Kg

300Kg

120Kg

26,7 m ±5% 30,3 m ±5% 32,3 m ±5%

26,7 m ±5% 30,3 m ±5% 32,3 m ±5%

26,7 m ±5% 30,3 m ±5% 32,3 m ±5%

26,7 m ±5% 30,3 m ±5% 32,3 m ±5%

